

SCREEN

BTN

ANGLED
DOWNWARD

NEEDS TO BE
WIDER

BAND
GOES OVER
THE WHOLE
DEVICE

FUNCTION
BUTTONS

OFF COVER
DISPLAY

BIG
KNOB

MAN BODY
BROKEN UP
INTO FOUR
PIECES.

STOP
STOP

* SQUARE FORMAT
EXPLORATION

UPPER
DOWN

MTL
PLATE
(HIGH GLOSS)

* CUT OUT
PIECE

OFF
CENTER

LONG KNOBS

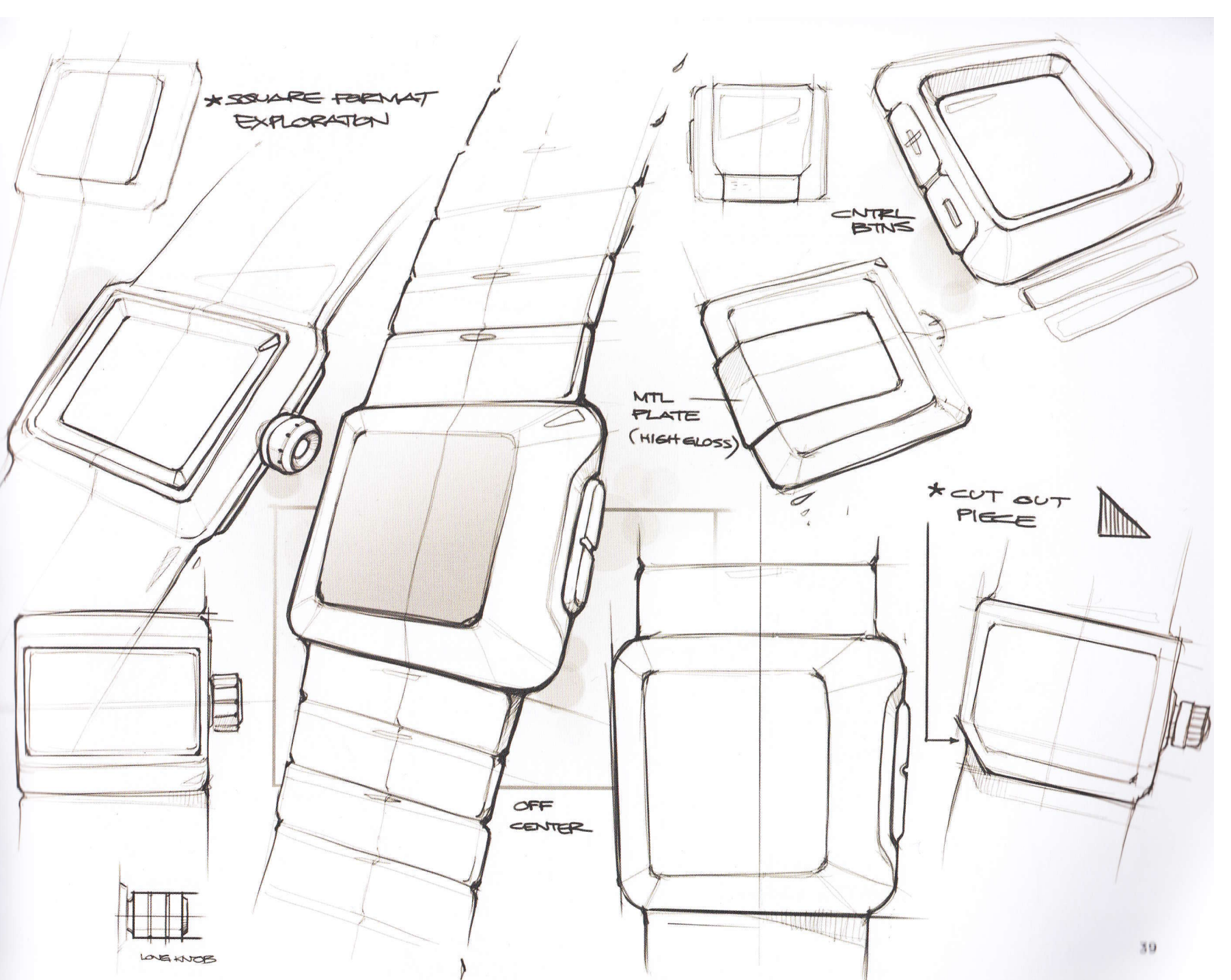

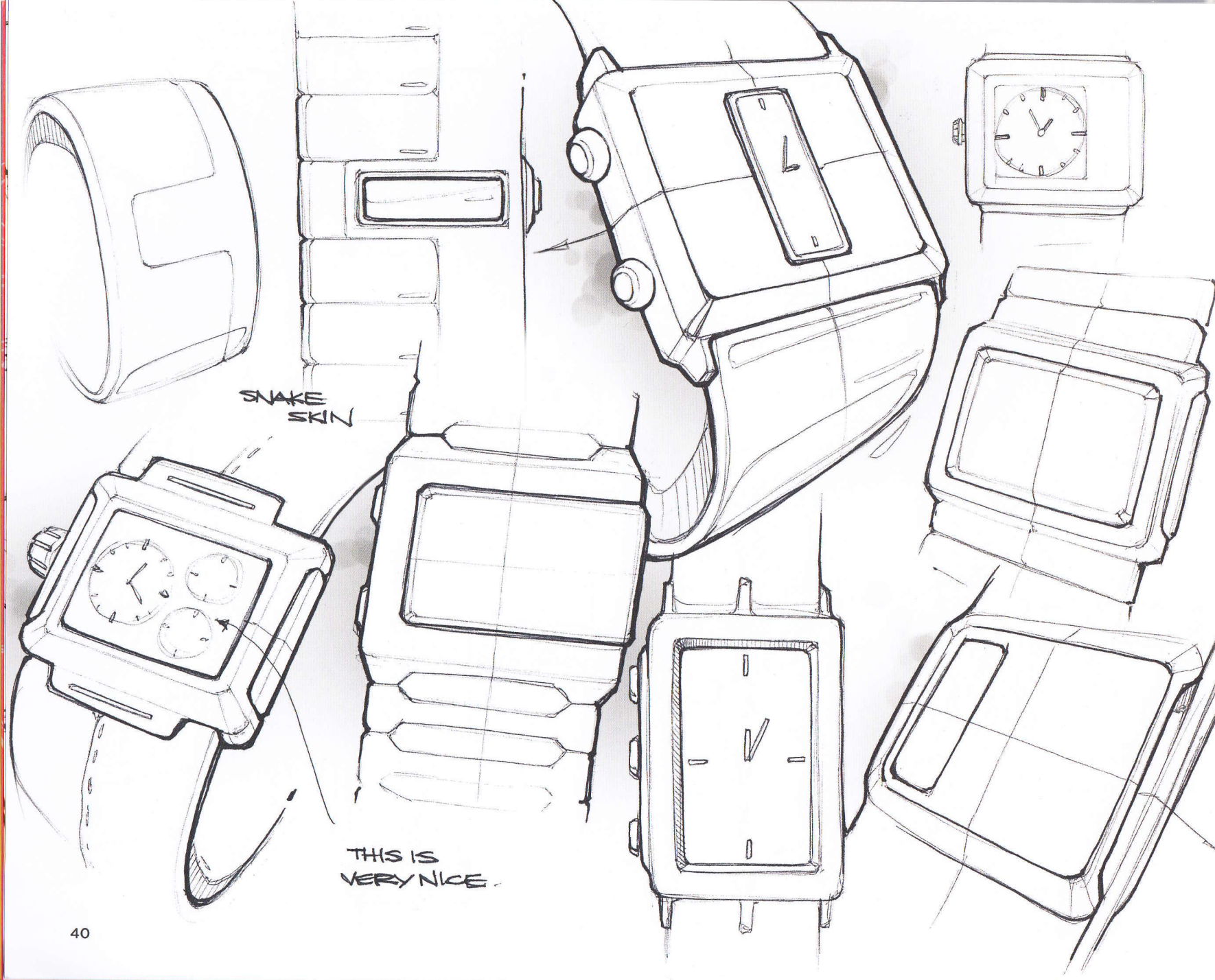

SKETCHES

THIS IS VERY NICE.

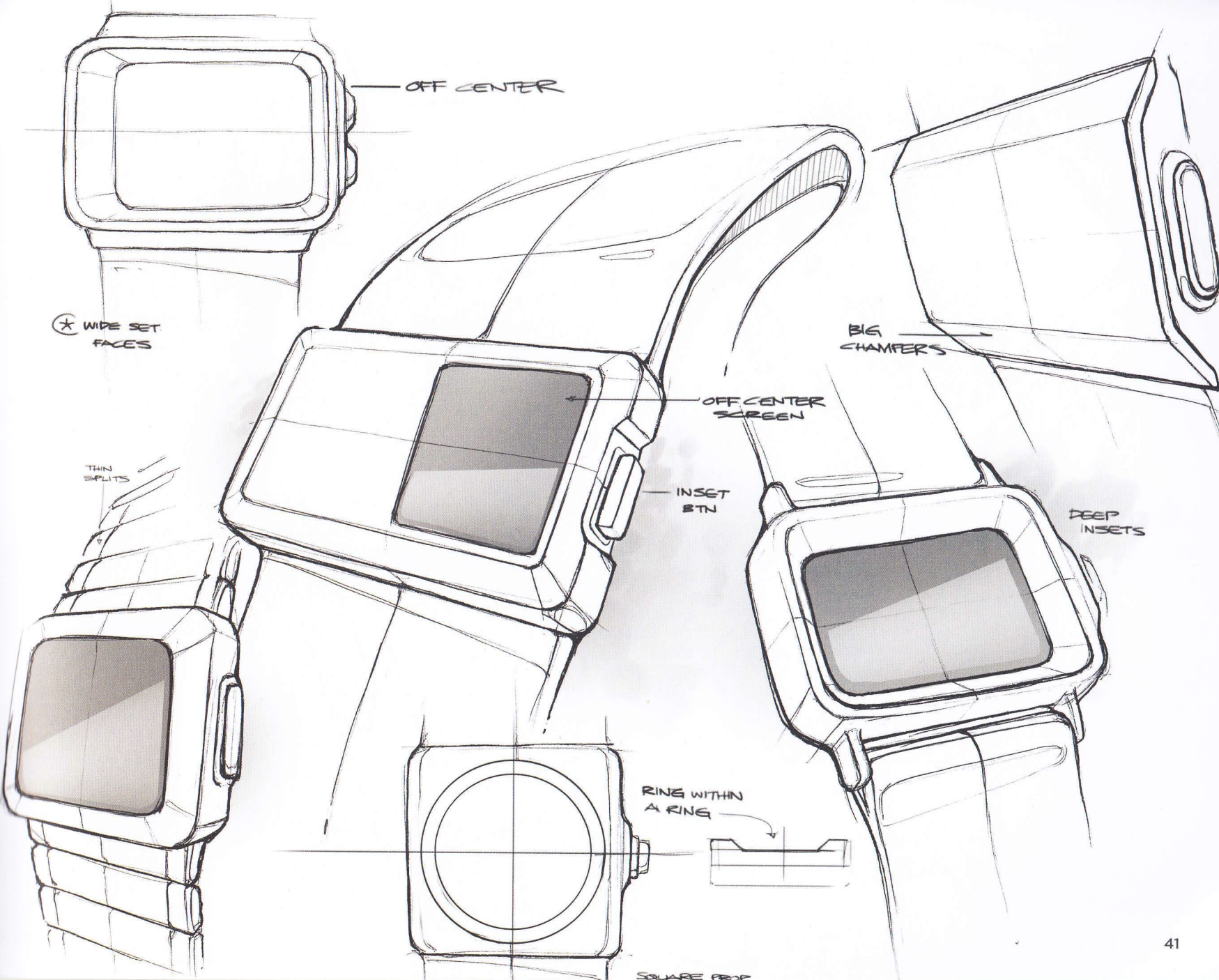

OFF CENTER

★ WIDE SET FACES

THIN SPLITS

OFF CENTER SCREEN

INSET BTN

BIG CHAMFERS

DEEP INSETS

RING WITH A RING

SQUARE PROF

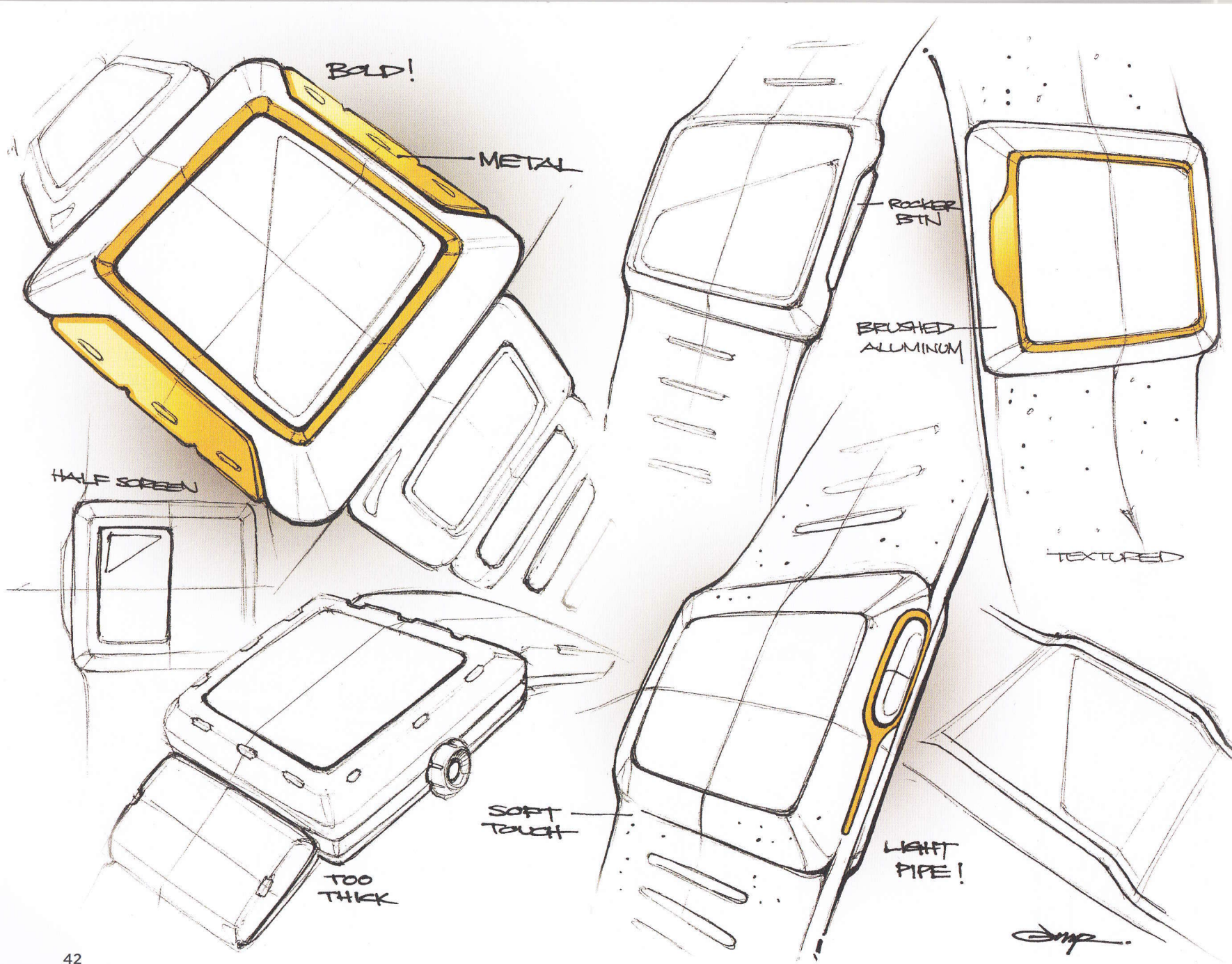

BOLD!

METAL

ROCKER
BTN

BRUSHED
ALUMINUM

HALF SCREEN

TEXTURED

TOO
THICK

SOFT
TOUCH

LIGHT
PIPE!

amp.

DECOR

WOOD INLAY

*FRONT VIEW...

... I FLIPPED IT.

LEATHER

WHAT ABOUT THE ARMS

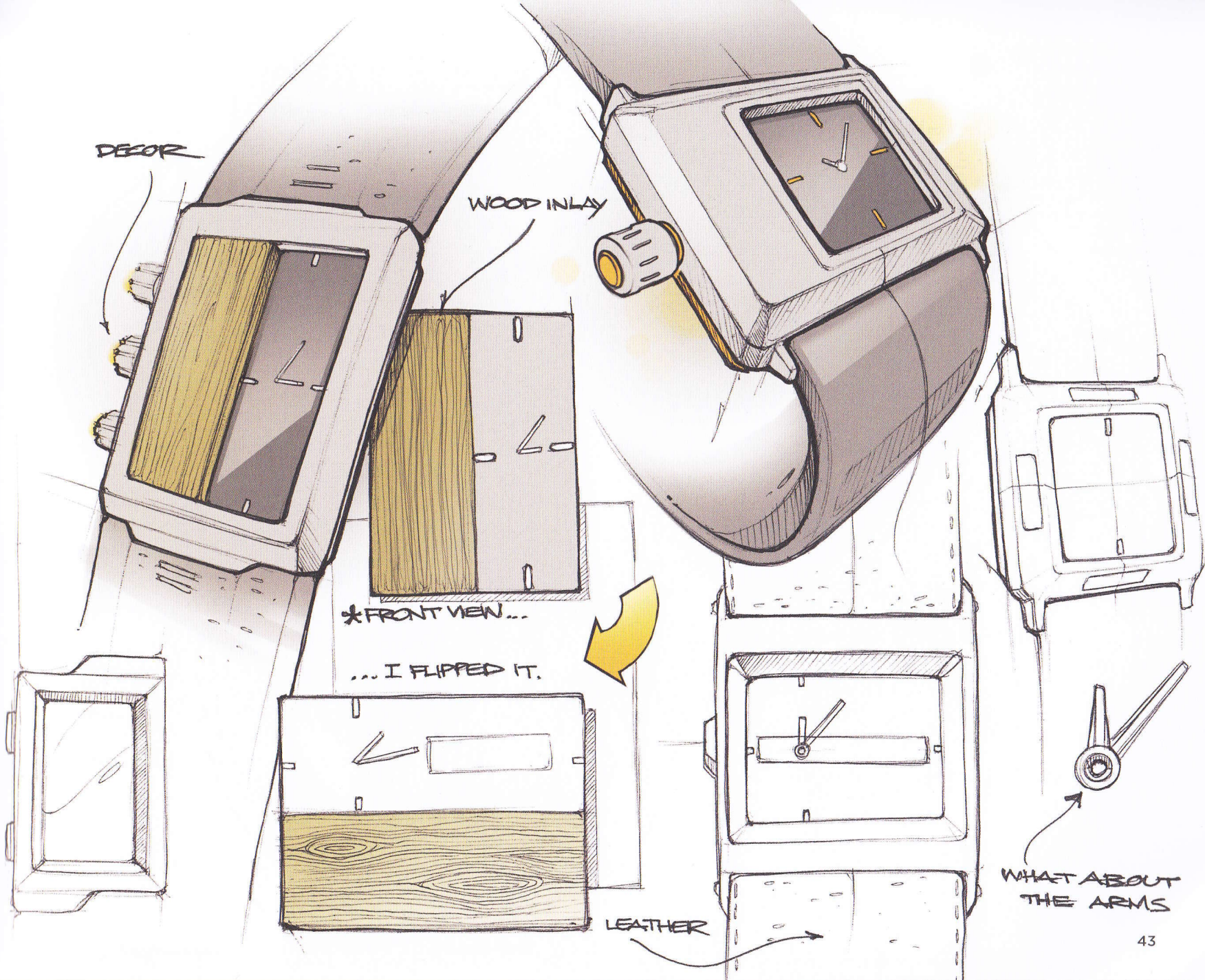

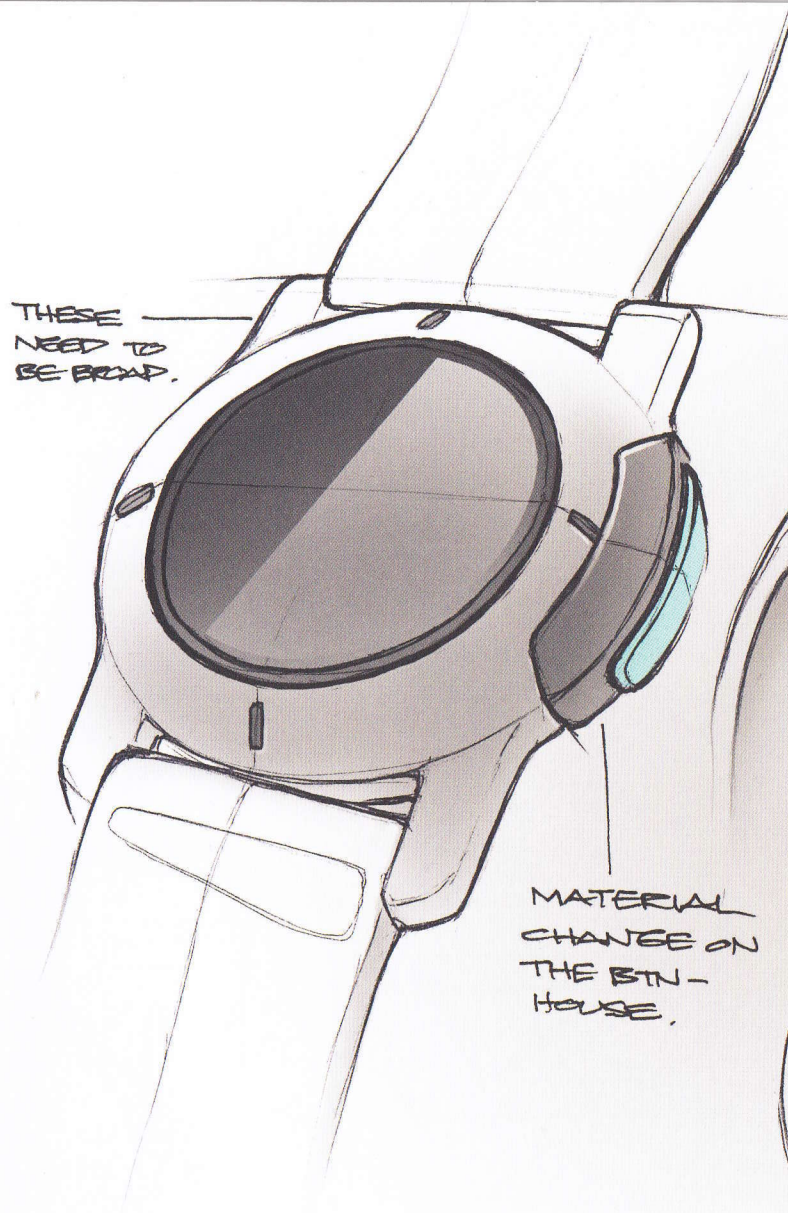

THESE
NEED TO
BE BROAD.

MATERIAL
CHANGE ON
THE BTN-
HOUSE.

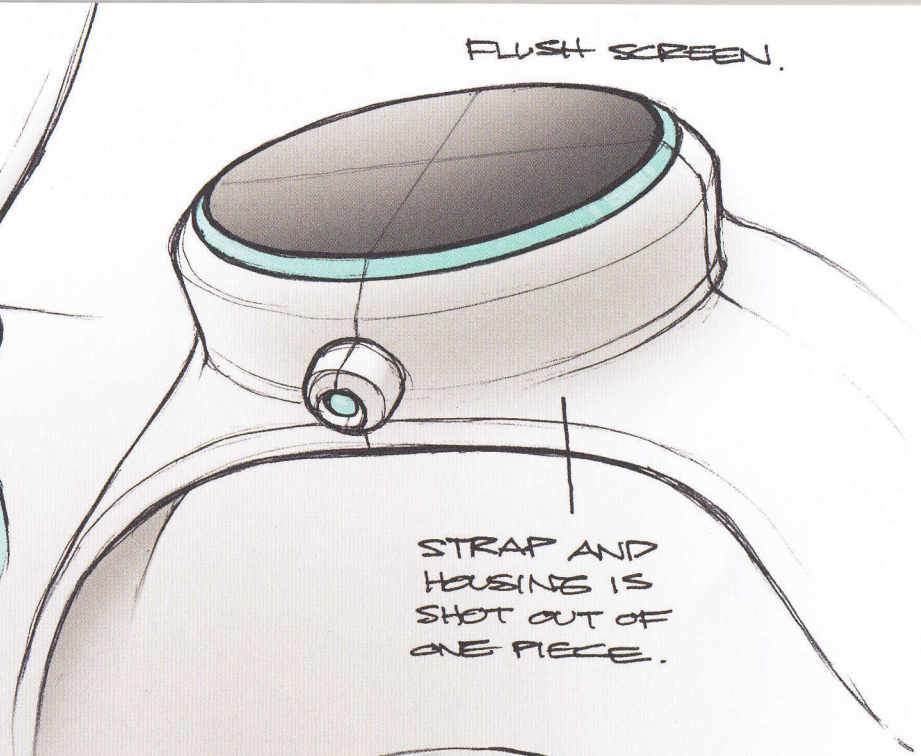

FLUSH SCREEN.

STRAP AND
HOUSING IS
SHOT OUT OF
ONE PIECE.

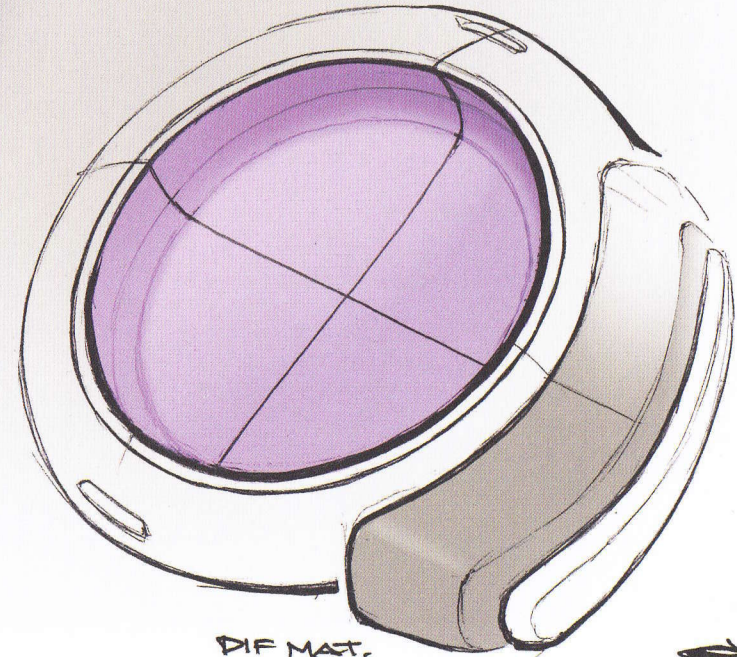

LRG BTN

DIF MAT.

* STRONG
"IN YOUR
FACE"
COLOR
SCHEME

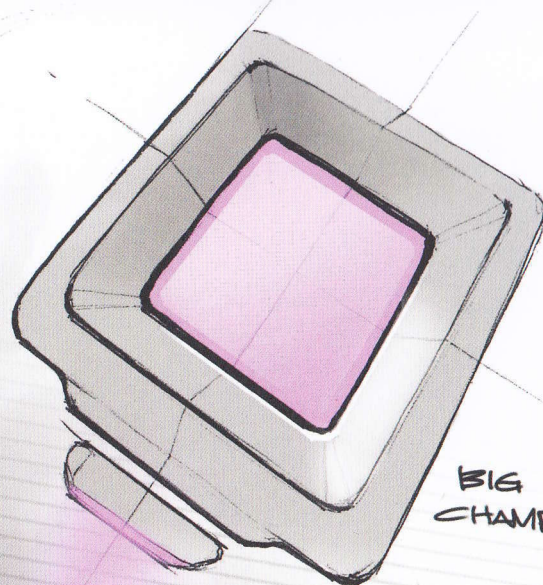
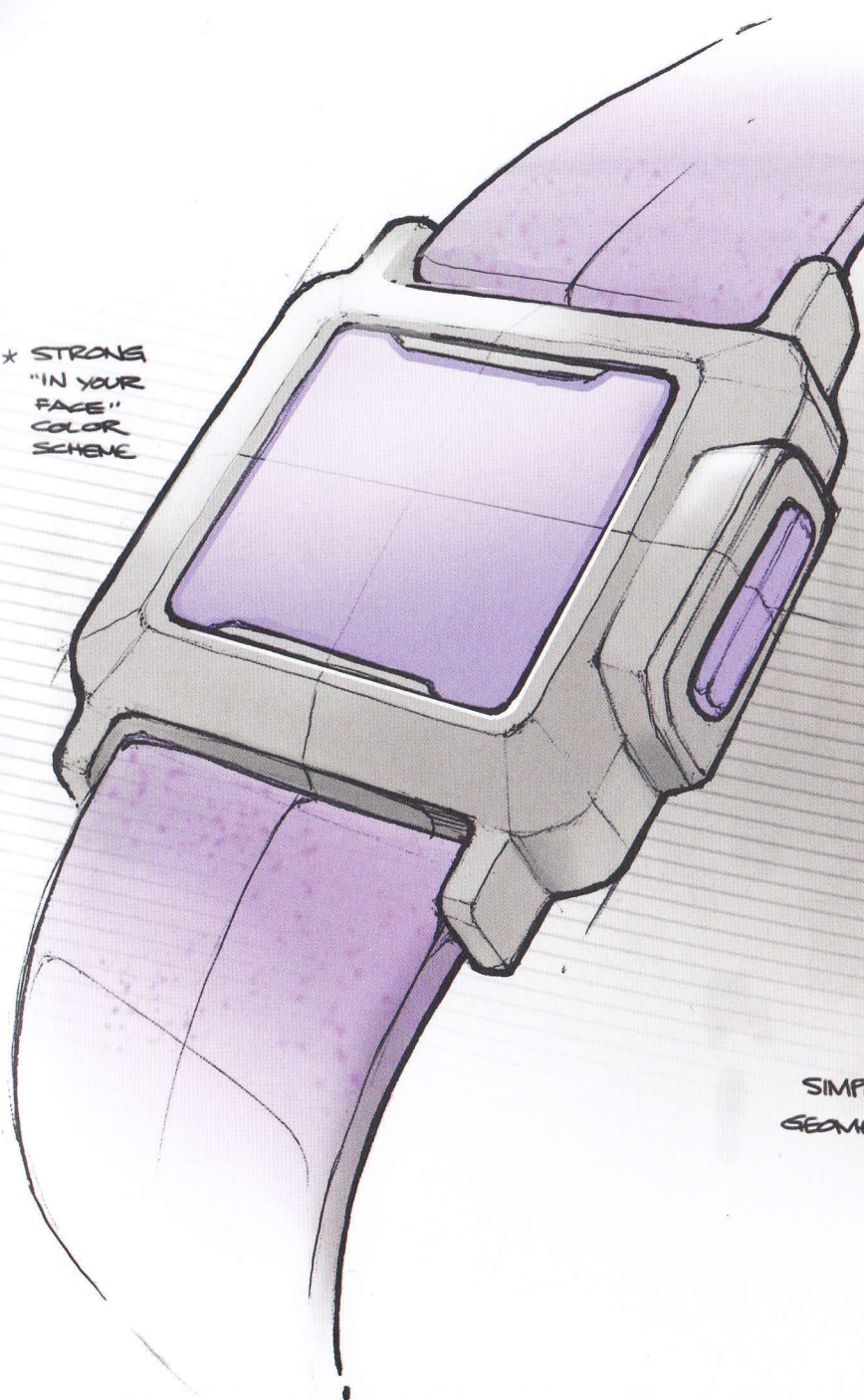

BIG
CHAMFER

SIMPLE
GEOMETRY

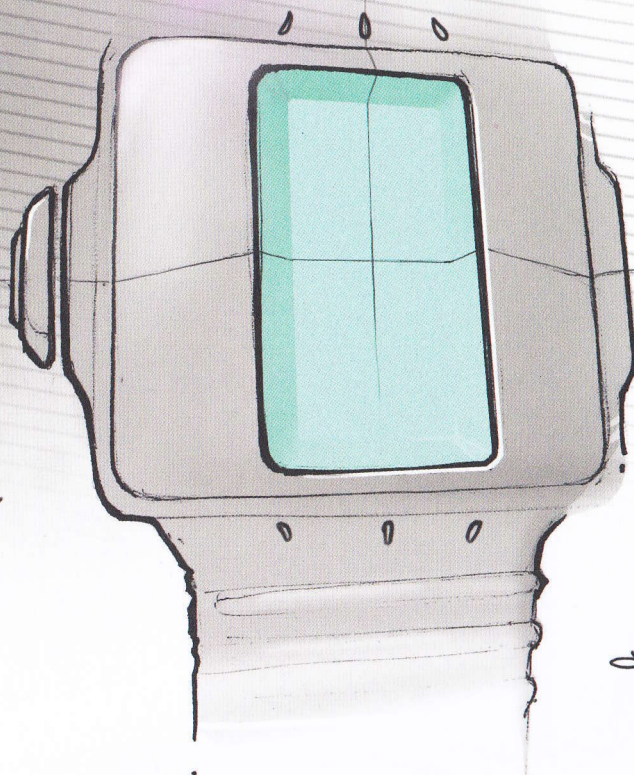

emp 2011

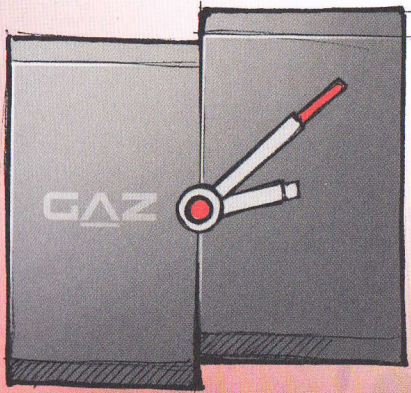

SPLIT FACE

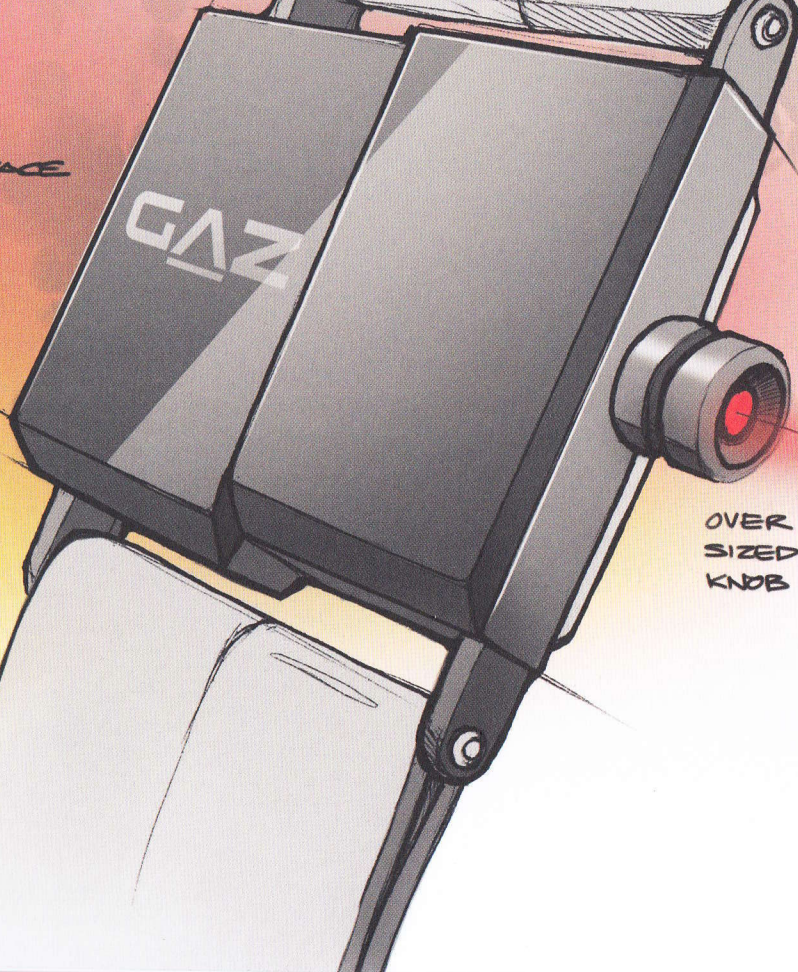

OVER
SIZED
KNOB

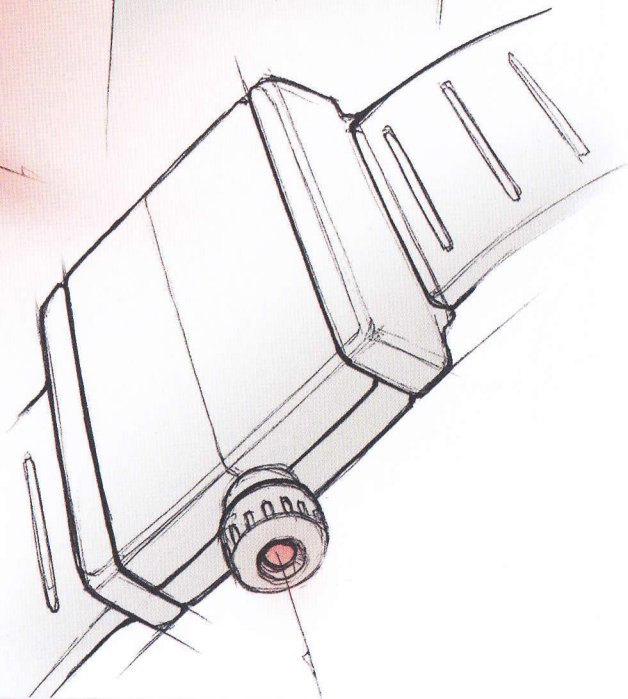
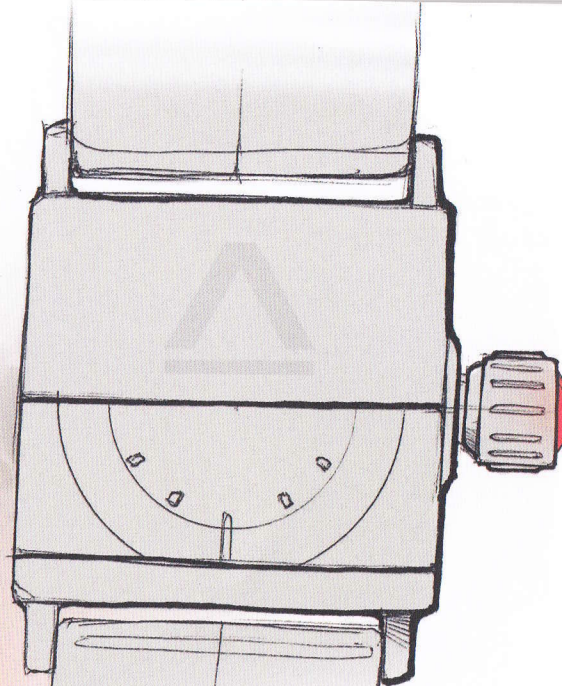

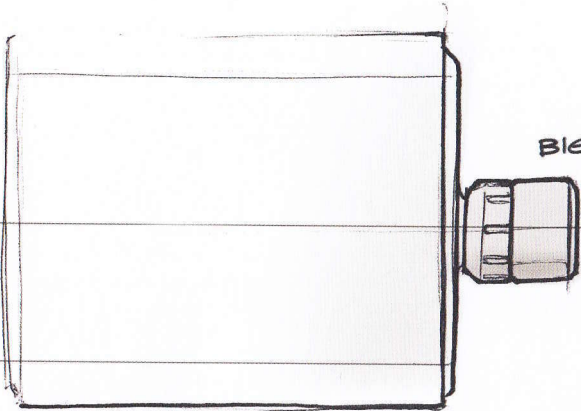

BIG KNDS

MATERIAL
BREAK

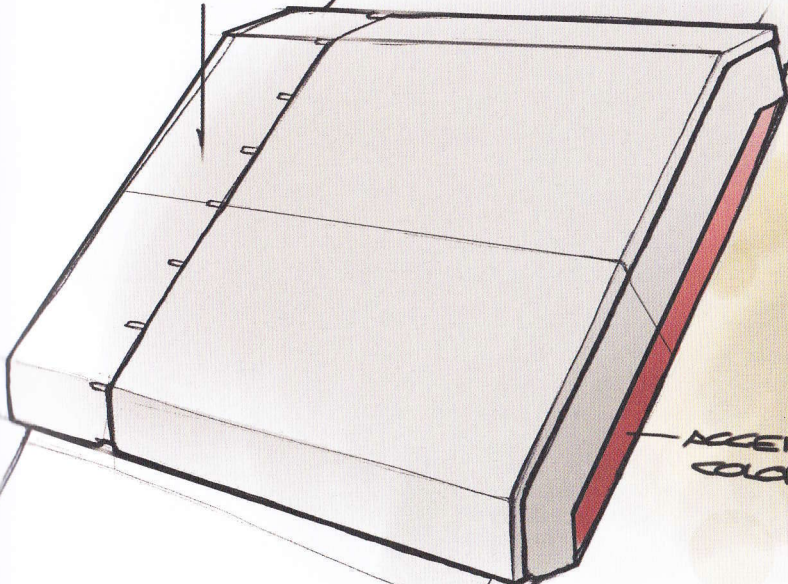

ASYMETRIC

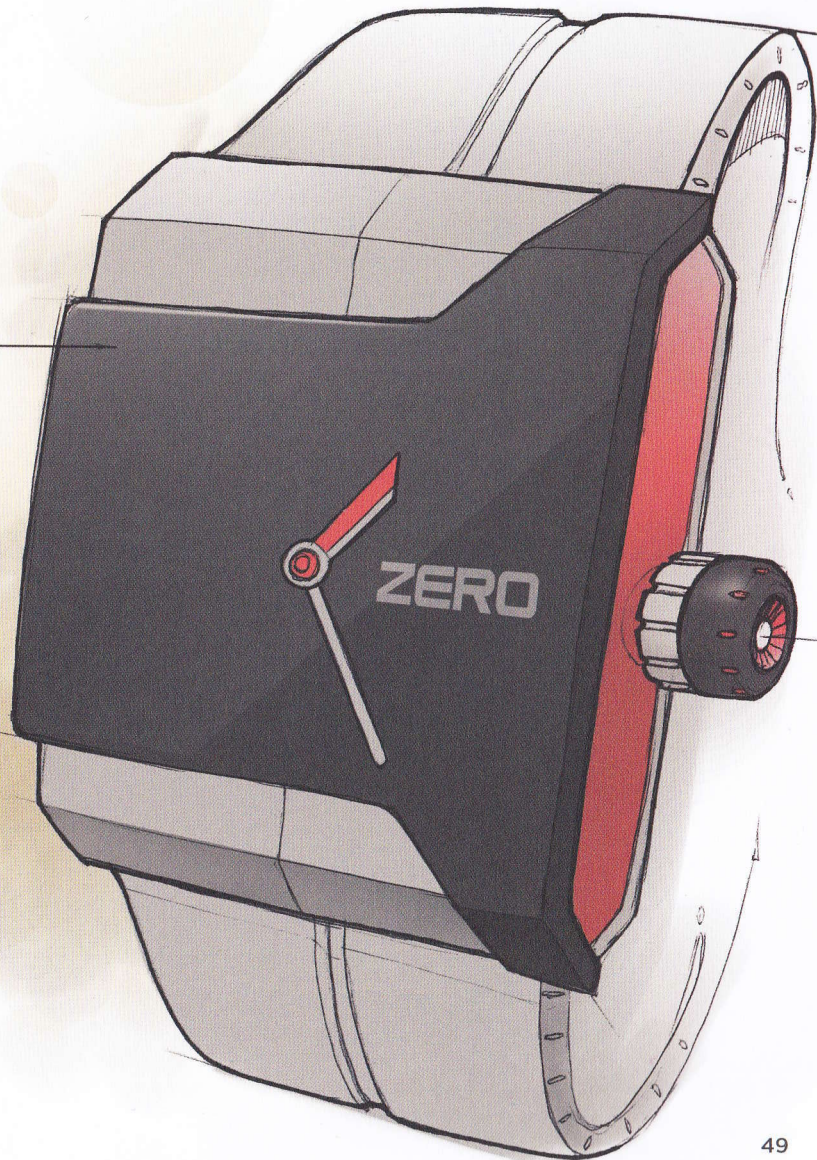

ACCENT
COLOR

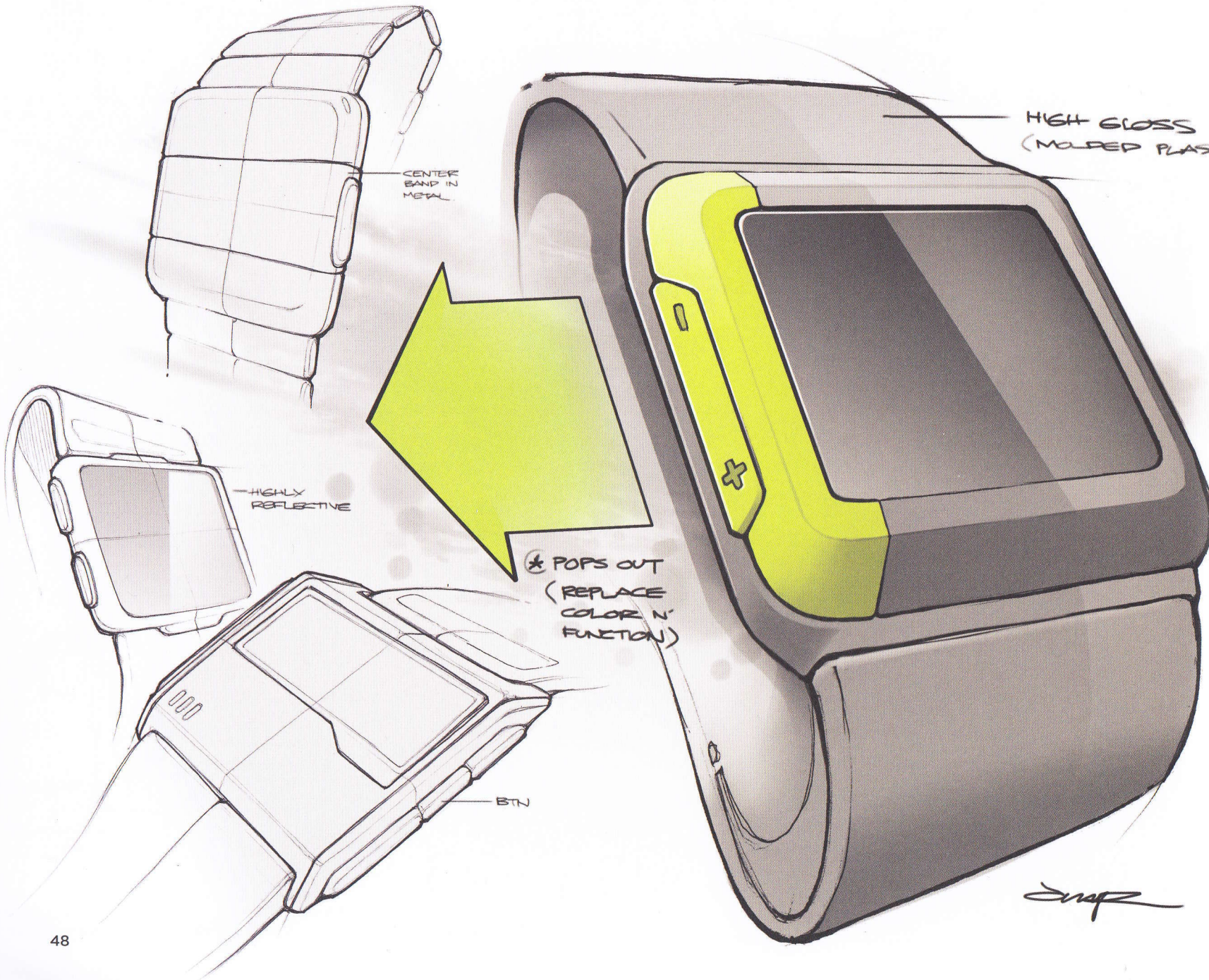

HIGH GLOSS
(MOLDED PLAS)

CENTER
BAND IN
METAL

HIGHLY
REFLECTIVE

* POPS OUT
(REPLACE
COLOR N'
FUNCTION)

BTN

DRAFT

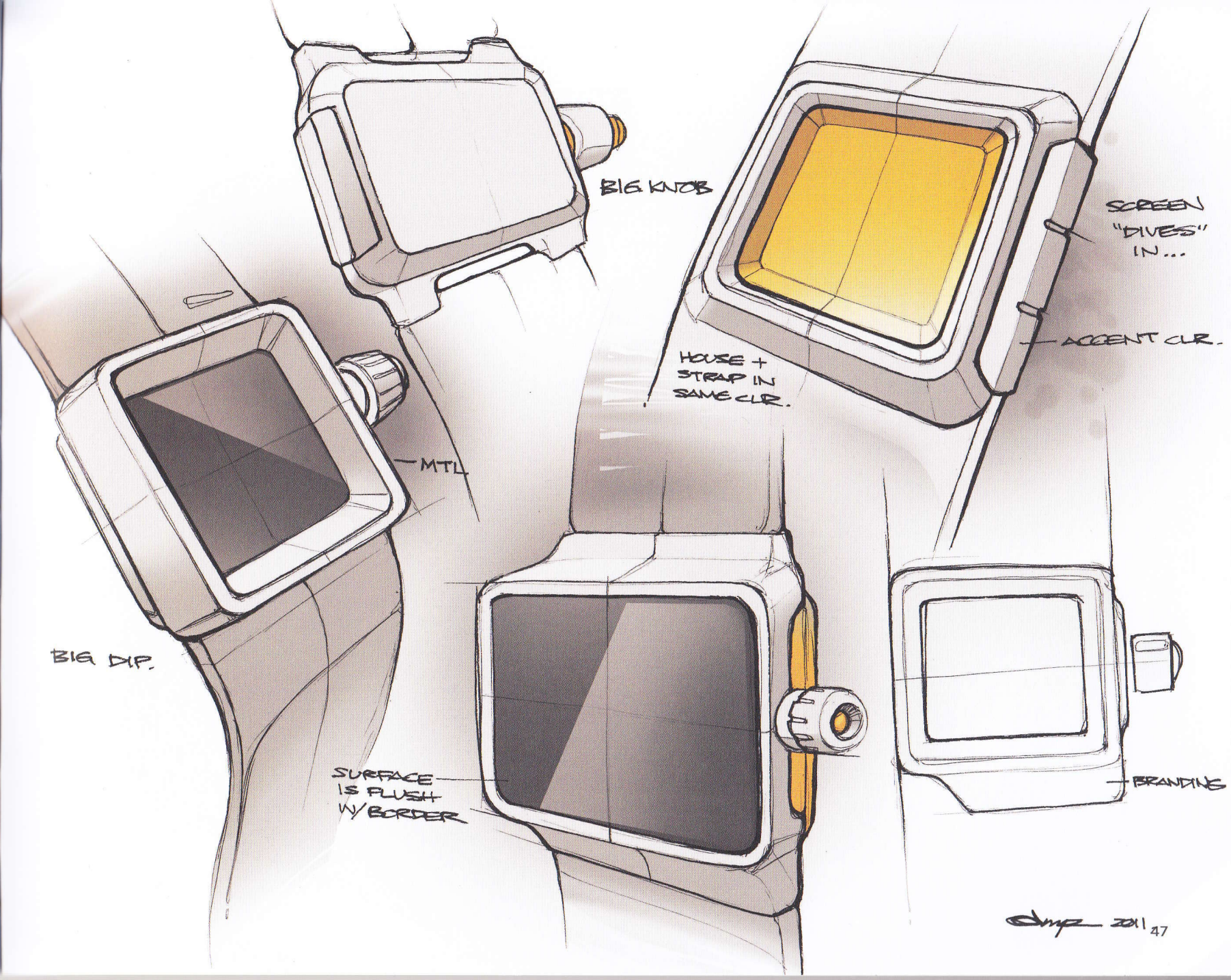

BIG KNOB

SCREEN
"DIVES"
IN...

ACCENT CLR.

HOUSE +
STRAP IN
SAME CLR.

MTL

BIG DIP.

SURFACE
IS FLUSH
W/ BORDER

BRANDING

*DIXY-WATCH
- SLEEK

SCREEN
POPS
OUT!

SPLIT
SCREEN

ACCENT
COLOR

HIGH
GLOSS

ROCKER
BUTTON

ACCENT
COLOR

POSSIBLE
COLORS:
- BLACK
- WHITE
- RED

201

ROCKER
BTN

BRUSHED
ALUMINUM

TEXTURED

WATCH SKIN

[Signature]

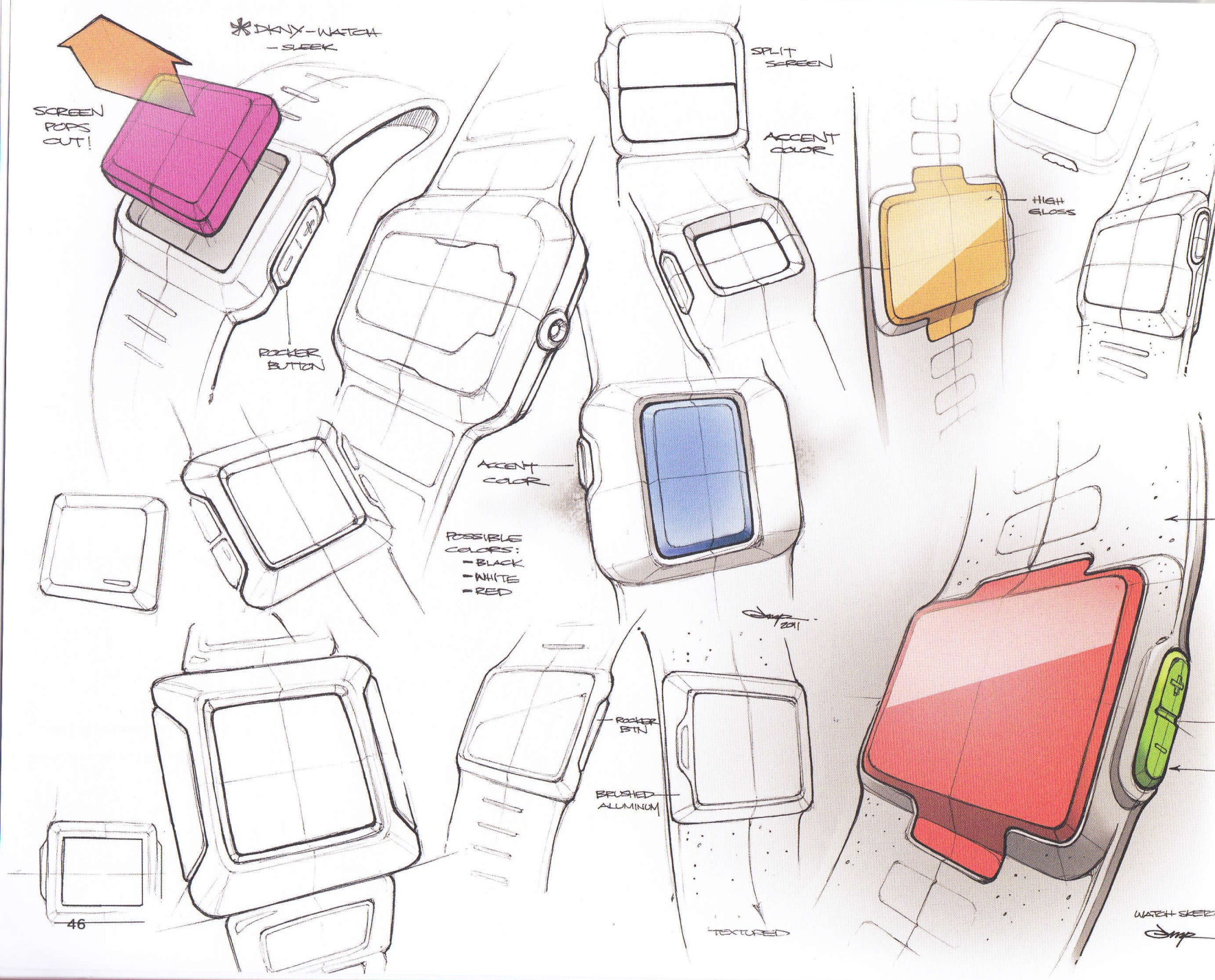

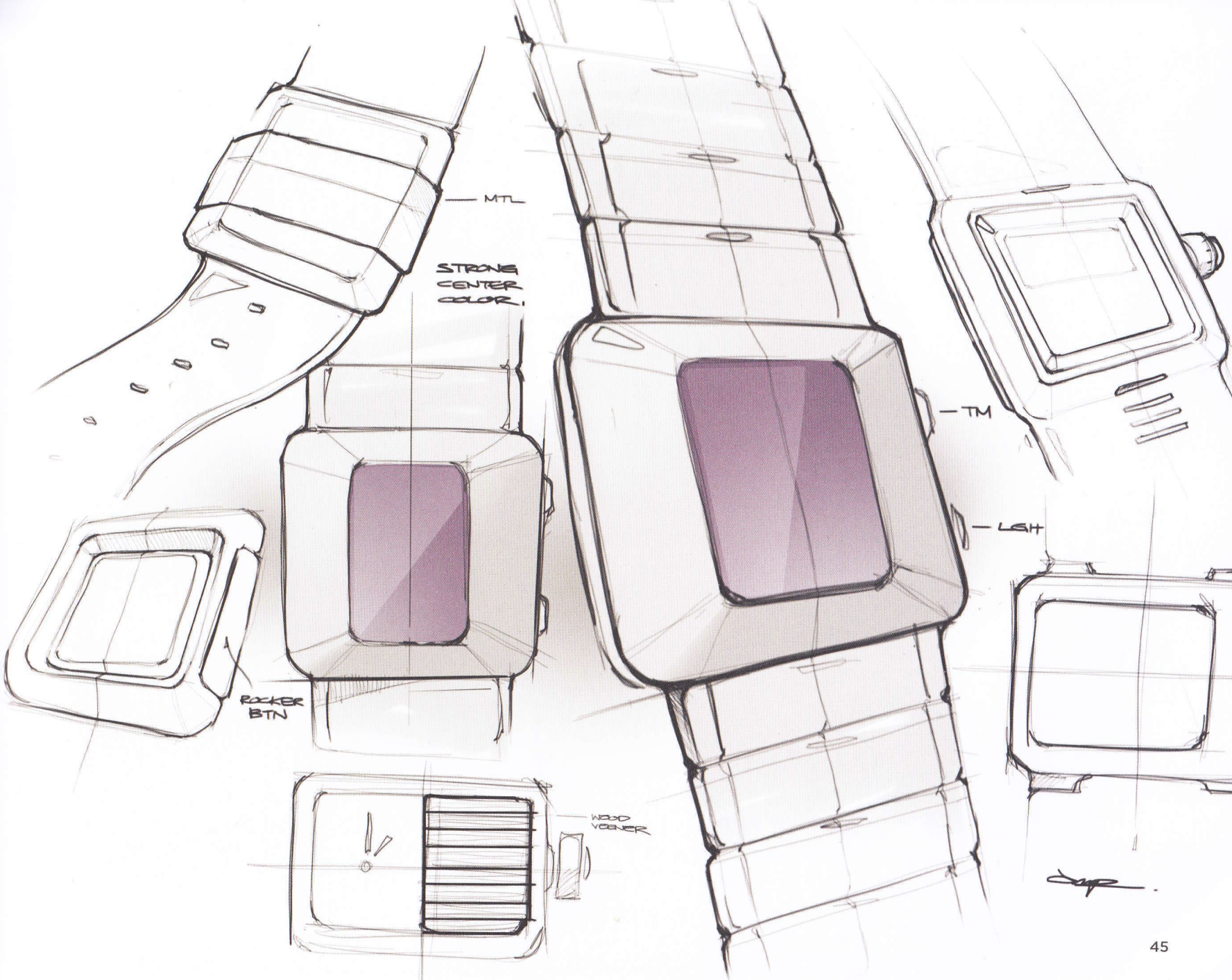

— MTL

STRONG
CENTER
COLOR!

ROCKER
BTN

— TM

— LST

TM
LST

[Signature]



amp 5.2011



MONDAY 22 MAY 2012

02:53

GALV

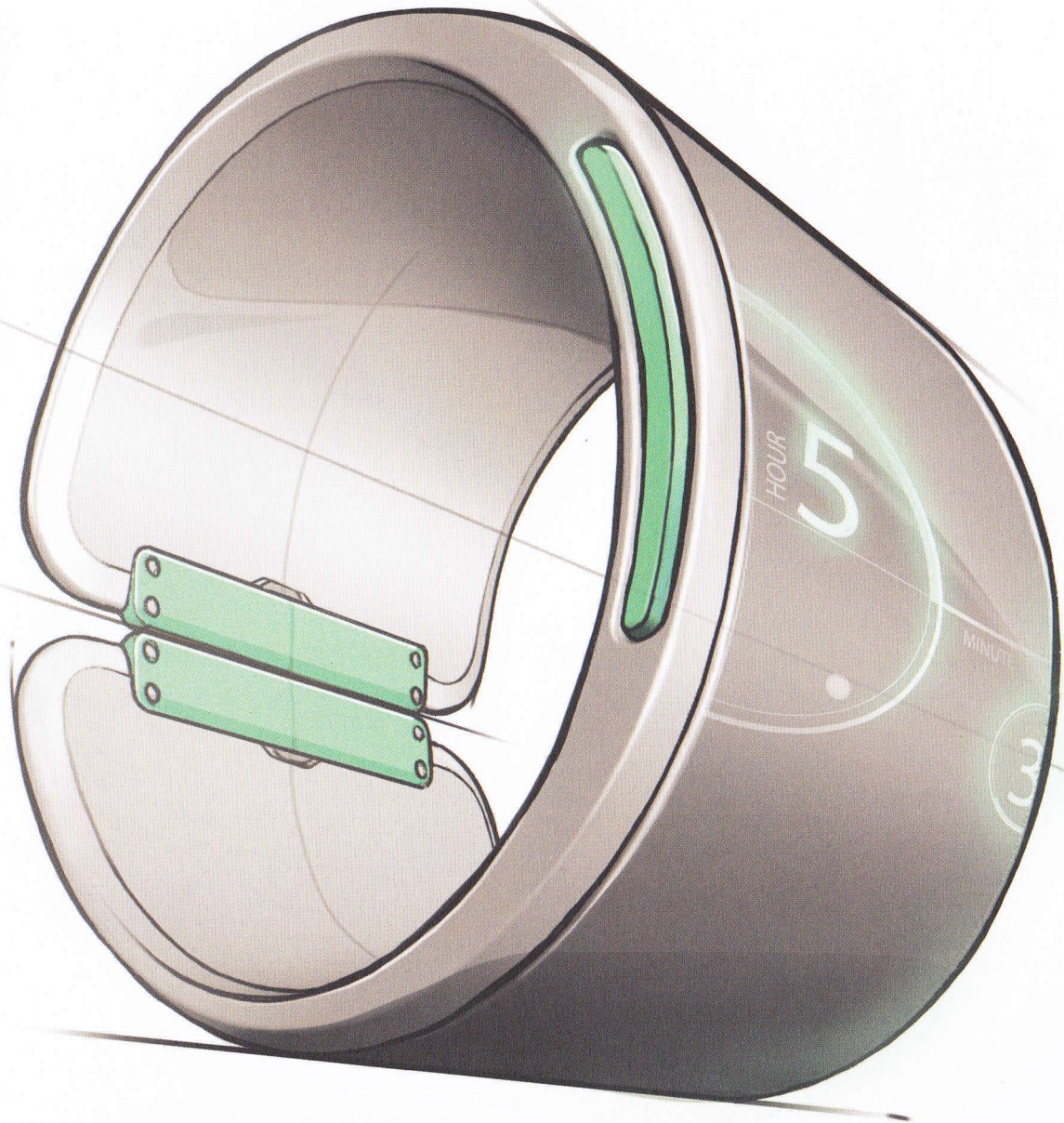



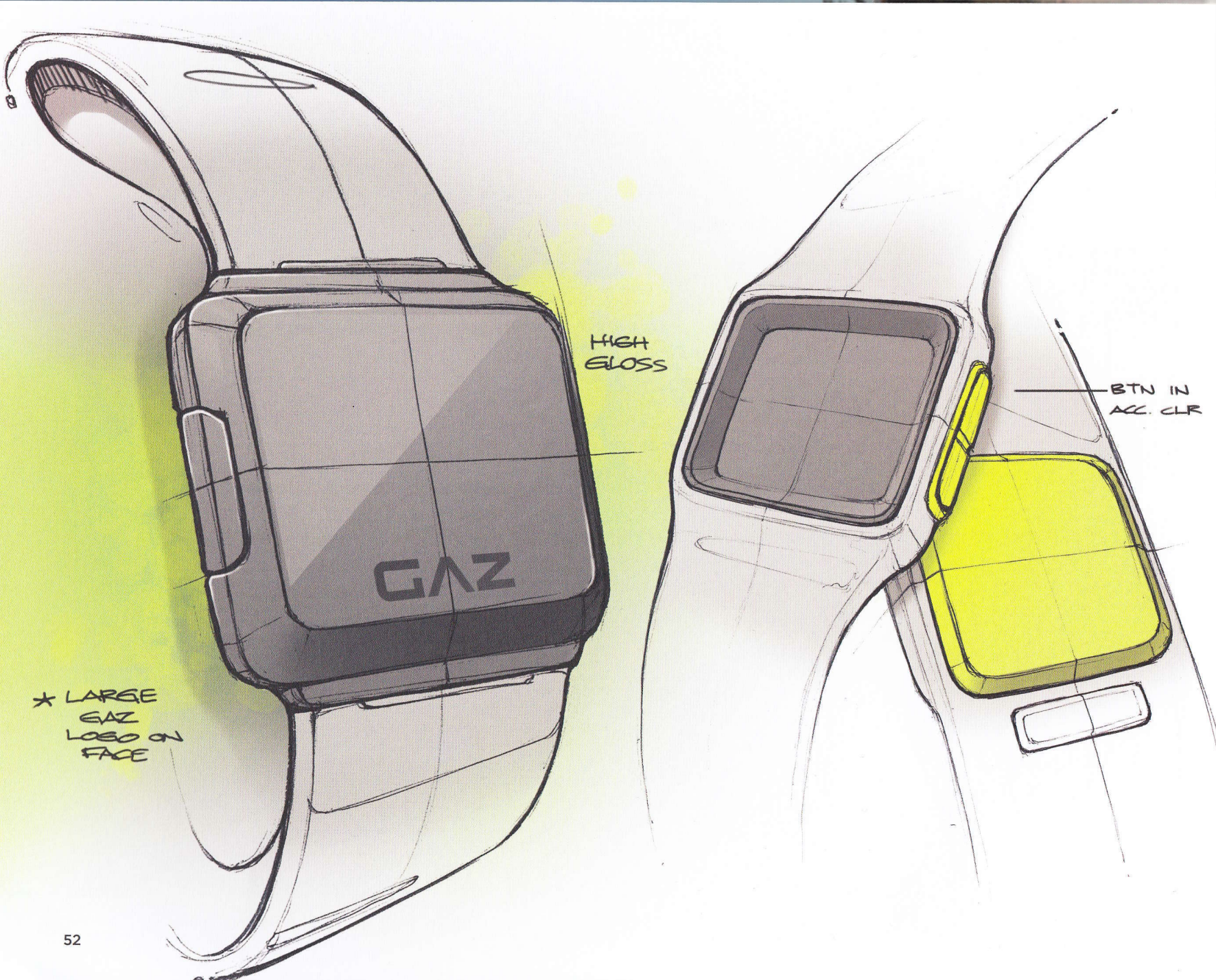

HIGH
GLOSS

BTN IN
ACC. CLR

* LARGE
GAZ
LOGO ON
FACE

